

November 2014

keeping you in the know

FMG POST



INSIDE:

PARTNERING FOR SUCCESS

*Why wire
maintenance
matters*

*Connect with
FMG online*

*Ag
scholarships
now open*

Note from Chris

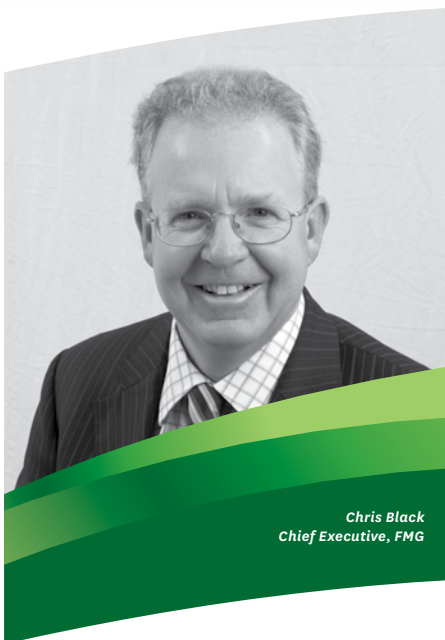

Chris Black
Chief Executive, FMG

It's heartening to have learnt recently that close to half of all farmers and growers across the country are now members of the Mutual.

As a mutual that's been around for 109 years, we appreciate that strong partnerships are an integral part of being successful over the long haul, whether that be on-farm or in a broader industry context. That's why we put a lot of store in the strategic partnerships we have with Farmlands and Federated Farmers – for the mutual benefit of rural New Zealand.

We have been working alongside Farmlands for over 80 years and it was an honour to recently be recognised as 'Farmlands Card Partner of the Year' again this year. Equally, we have worked closely with Federated Farmers for well over 100 years on key issues of mutual interest, a good example being the work we are currently doing with their policy team to better understand the regulatory and compliance risks farmers and growers face in their daily operations. Using that knowledge, we are able to help clients better assess those risks and advise them – often enlisting the help of third-party experts - on how they might manage them.

Following last year's spring storms, we took a similar approach and partnered with Irrigation NZ and Lincoln University to better understand the risks associated with managing irrigators in high and unpredictable winds. Based on learning from last season, we have also enhanced the products and services available to support farmers and growers with irrigators. You can read more about the results of this partnership inside.

Keeping an eye on the future is important too and we're proud to be able to offer agricultural scholarships and support organisations like Young Farmers and Nuffield New Zealand. We also invest in developing the business, leadership and governance skills of women through the Agri-Women's Development Trust.

Helping rural New Zealand get a better deal when it comes to risk advice and insurance is something we pride ourselves on as an organisation, and so it was heartening to learn recently that close to half of all farmers and growers across the country are now members of the Mutual. We value the opportunity to serve and support you - as well as our wider client base - through both buoyant as well as tougher times.

All the best for the summer months.

Chris Black
Chief Executive, FMG



Partnering for Success: Working together for the rural community

Although geographically spread, the rural community remains one of the most supportive, connected, loyal and unique networks in New Zealand.

Whether you or your family are involved with the local school, regional Young Farmer's branch, sports club, dog trials, industry discussion group or neighbourhood network, these connections, friendships and support are in one way or another enablers of rural achievement.

“Connections, friendships and support are the enablers of rural achievement”

In the same way that you look towards the community to support your farming business we too look to forge partnerships with other organisations that understand rural and get what you're trying to achieve.

Our partnerships with Federated Farmers, Farmlands, NZ Young Farmers, Taratahi Agricultural Training Centre and the Agri-Women's Development Trust are examples of this.

Federated Farmers is New Zealand's leading advocacy group for farmers and FMG has supported them for more than 100 years.

We support them because we believe in their advocacy work and the importance of working with industry and the community for the benefit of all farmers. Having access to the country's farming network means they can keep their ear close to the ground on the issues, pressures and opportunities facing the industry.

We not only support them at a national level as a Gold Sponsor, but are also the only sponsor to directly support each of their 24 provinces. These provincial payments support local Federated Farmers activities and events – such as the recent health and safety seminars and sharemilker workshops.

Another organisation we have a long history with is Farmlands, who we've worked alongside for 80 years. We're closely aligned in that we were both started by farmers for farmers to give rural New Zealand a better deal. Our partnership helps Farmlands bring a range of events to rural areas and offers Farmlands shareholders a rebate on FMG premiums when paying through their Farmlands account.

As well as partnering with organisations such as Farmlands and Federated Farmers, we're also committed to giving back to the rural sector.

An example of this is through our tertiary-level and Taratahi Agricultural Training Centre scholarships.

We think supporting rural women is also important and work with Agri-Women's Development Trust, whose programmes encourage women to further develop and apply their leadership, business and governance skills.

“Strong partnerships play a key role in helping rural New Zealand succeed”

Strong partnerships and support networks will always play a key role in helping rural New Zealand succeed. That's why we continue to work with organisations to explore how we can further support you. On that front we're currently developing a new partnership with the Mental Health Foundation – specifically in relation to jointly supporting wellbeing in rural communities.

We look forward to sharing more details about this new partnership next year, and how it could support you, your family, and your rural community.



Reducing irrigator damage

Over the past several months FMG has been working with research experts Lincoln University to study the preventative measures farmers and growers took to protect their irrigators during last spring's Canterbury windstorms.

FMG invited more than 400 farmers and growers with irrigators in the region to take part in a survey. They were asked what they did and didn't do to secure their irrigators in the days and hours leading up to the winds striking.

The Advice Guide can be found on our new website and highlights the precautionary steps you can take ahead of a major wind storm. It also looks at steps you can take all year round to help prevent damage.

Key findings taken from the report

Three out of four respondents felt that parking the irrigator longitudinally down or into the wind during the storm significantly helped reduce damage.

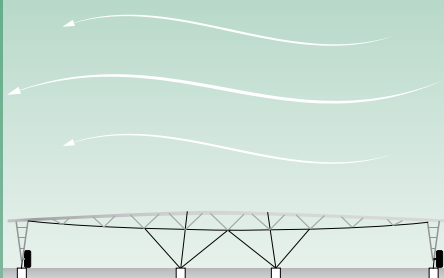

Owners noticed irrigators tend to “bounce” before they fall over. To minimise this vulnerability, tie your irrigator down at the base beam of each tower and use strops midway over each span.

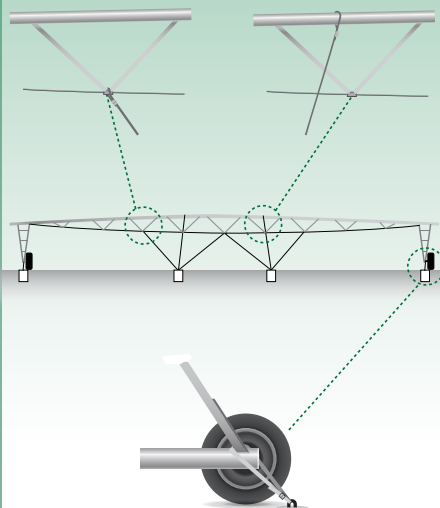
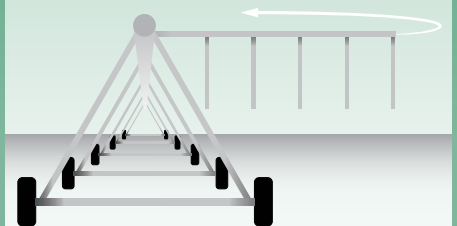

Diagram based on image from Waterforce

Corner arms and overhang were found to be the most sensitive elements of the pivot system and if left at a 90 degree angle, would increase the likelihood of tipping. Lightly stropping the end of the overhang to a suitable anchor helps reduce bouncing and prevents fatigue.



Getting down to the wire

Summer is a great time to carry out maintenance and check for any damage that winter may have left behind. But one aspect of maintenance that is sometimes overlooked is hidden electricals.

Over the wetter, colder months your switchboards can fall victim to water damage or even hungry rodents.

To help you check the integrity of your switchboards, you may wish to consider thermal imaging. Thermal imaging helps detect electrical weaknesses – the hotter an object's temperature, the more thermal energy it emits, which usually indicates faulty wiring and the risk of fire.

We partner with thermal imaging company Thermoman to help clients identify the risk of fire in their large farm buildings, including milking sheds. The testing uses high-tech thermal imaging cameras and is non-intrusive, but can alert you to an imminent fire risk.

Over the last few years, FMG has assessed over 920 dairy and commercial sites for 680 clients. Of these assessments, 7% were in immediate danger of fire while a further 42% needed some form of remedial work to reduce the fire risk.

If you have a large farm building and are interested in receiving a thermal imaging consultation, please get in touch with your local FMG representative for more information or call 0800 366 466.

FMG Agriculture Scholarship now open

Applications for FMG's Agriculture Scholarship are now open. This year, we've expanded our eligible degree options and have included Waikato University.

These additions to our scholarship programme recognise the expanding opportunities the agricultural sector provides and also highlights the skills and expertise required to continue promoting excellence in the industry. Our expanded offering now includes majors in agritech, agri food marketing and rural land and property management on top of the traditional agricultural sciences and agribusiness degrees.

The scholarship is open to students entering the first year of agriculture-

based degrees at Massey, Lincoln or Waikato universities. Recipients receive \$4000 towards their tuition fees for each year of their degree, with two scholarships awarded each year.

Applications close on 15 December. To find out more or to apply for the scholarship, head to www.fmg.co.nz/scholarships or call 0800 366 466.

Are you already in the agriculture industry and looking to develop your leadership skills?

We're a proud Sponsor of The Nuffield Farming Scholarship Trust, which has

recently combined resources with Lincoln University to improve the leadership capability within the rural and primary industry sectors in New Zealand. This 'Kellogg Rural Leadership Programme' is a six month course designed to develop your leadership skills,

provide networking opportunities and boost your industry expertise.

Applications for next year's intake close in March 2015. Find out more at www.kellogg.org.nz



Congratulations to Nuffield NZ's 2015 Scholars

As part of our commitment to learning and development within the agricultural sector, FMG supports the Nuffield scholarship – New Zealand's most prestigious scholarship for leaders in the rural sector.

Nuffield NZ has recently announced its 2015 scholars and we would like to extend our congratulations to the five recipients. We wish them all the best for their travel and studies, and look forward to continuing our partnership with them and the scholarship programme.

From left to right: FMG's National Sales Manager Emma Thomas with Nuffield scholars Bede O'Connor, Sharon Morrell, Ben Allomes, Satwant Singh, Dan Steele and FMG's General Manager Advice & Insurance Conrad Wilkshire.



Connecting with you online

Weather watch

We can't control the weather, but we can help you see it coming with FMG's rural weather app.

The free app – which we created in conjunction with MetService – is tailored to rural regions in New Zealand and includes severe weather warnings and forecasts from two-hourly up to 10 days. It also gives you direct access to some of our weather risk advice.

We're proud to have helped over 50,000 people predict the weather from their pockets and we can help you too. Download your free app from the IOS or Android store.



New FMG website

FMG has launched its new website which will provide you with greater access to our advice, products and information from any internet friendly device. Whether you're on the home computer, laptop, tablet or your smartphone, you'll be able to check in with or contact FMG at any time.

Some of the site's new features include:

- Starting a claim or quote online
- Upcoming rural events
- More information about our policies
- An advice section sharing our learnings on and off farm

Check out our new website at www.fmg.co.nz

Introducing FMG's Facebook page

FMG's gone social and we want you to join the conversation! Head to our FMG Advice and Insurance Facebook page to connect with your mutual and engage with us on rural events and topics.



FarmersMutualGroup



We're easy to contact

Call us on
0800 366 466

Write to us at
PO Box 1943
Palmerston North 4440

Email us
contact@fmg.co.nz

Visit our website
www.fmg.co.nz



FarmersMutualGroup